



Designation: C627 – 10^ε¹

Standard Test Method for Evaluating Ceramic Floor Tile Installation Systems Using the Robinson-Type Floor Tester¹

This standard is issued under the fixed designation C627; the number immediately following the designation indicates the year of original adoption or, in the case of revision, the year of last revision. A number in parentheses indicates the year of last reappraisal. A superscript epsilon (ϵ) indicates an editorial change since the last revision or reappraisal.

^ε¹ NOTE—Revised 5.4 editorially in July 2017.

1. Scope

1.1 This test method covers the evaluation of ceramic floor tile installation systems, using the Robinson²-type floor tester.

1.2 This test method is intended solely for evaluating complete ceramic floor tile installation systems for failure under loads and not for evaluating particular characteristics of ceramic tile, such as abrasion resistance. This test method does not claim to provide meaningful results for other than evaluating complete ceramic floor tile installation systems.

1.3 The values stated in inch-pound units are to be regarded as the standard. The metric (SI) units in parentheses are for information only.

1.4 *This standard does not purport to address all of the safety concerns, if any, associated with its use. It is the responsibility of the user of this standard to establish appropriate safety and health practices and determine the applicability of regulatory limitations prior to use.*

1.5 *This international standard was developed in accordance with internationally recognized principles on standardization established in the Decision on Principles for the Development of International Standards, Guides and Recommendations issued by the World Trade Organization Technical Barriers to Trade (TBT) Committee.*

2. Referenced Documents

2.1 *ASTM Standards:*³

C144 Specification for Aggregate for Masonry Mortar

C150 Specification for Portland Cement

¹ This test method is under the jurisdiction of ASTM Committee C21 on Ceramic Whitewares and Related Products and is the direct responsibility of Subcommittee C21.06 on Ceramic Tile.

Current edition approved Sept. 1, 2010. Published September 2010. Originally approved in 1970. Last previous edition approved in 2007 as C627 – 93 (2007). DOI: 10.1520/C0627-10E01.

² Developed at the Research Center of the Tile Council of America, Inc. Detailed working drawings of the apparatus are available at a nominal cost from ASTM Headquarters. Order Adjunct No. ADJC062701.

³ For referenced ASTM standards, visit the ASTM website, www.astm.org, or contact ASTM Customer Service at service@astm.org. For *Annual Book of ASTM Standards* volume information, refer to the standard's Document Summary page on the ASTM website.

2.2 *ASTM Adjuncts:*

Robinson-type Floor Tester²

Deflection Gage⁴

3. Summary of Test Method

3.1 This test method consists of preparing installation slabs that duplicate the type of installation under consideration, subjecting them to one or more tests on the Robinson floor tester, and evaluating the results in a prescribed manner. Description of the installation method must specifically include all variables, for example, the type of materials and mixture proportions of substratum, setting material, and tile grout; type of tile, installation technique, and cure.

4. Significance and Use

4.1 This test method provides a standardized procedure for evaluating performance of ceramic floor tile installations under conditions similar to actual specific usages. It can be used to make comparisons between customary basic installation methods, to establish the influence of minor changes in a particular installation method, and to judge the merit of proposed novel methods.

5. Apparatus

5.1 *Foundation for Tester*—The foundation for the tester shall consist of a nominally 4-ft (1220-mm) square and 1-ft (300-mm) thick cement slab with two 15- by 15-in. (380- by 380-mm) bearing plates with four 12½-in. (318-mm) high tie rods cast into the center of the foundation and with an 8-in. (203-mm) square and 1-ft (300-mm) deep opening in the exact center. The top surface of this slab shall be smooth, level, and flat with the maximum deviation from a true plane not to exceed 1/32 in. (0.8 mm). An extension at the bottom of one side of the foundation shall be approximately 4 in. (102 mm) thick and 14 in (356 mm) wide to hold the motor, speed reducer, and drive. A 4-in. high and 8-in. wide tunnel, running from the top of the cement extension and level with it to the center of the

⁴ Detailed working drawings for construction of the deflection gage are available at nominal cost from ASTM Headquarters. Order Adjunct No. ADJC062702.

1-ft thick foundation slab permits the transmittal of the drive to the carriage of the tester. Four 3/4-in. (19-mm) holes, 2 1/2 in. (63.5 mm) deep to hold 1/2-in. (12.7-mm) threaded lead shields (Star Tamp-Ins) shall be cast into the foundation, one at each corner and located 5 in. (127 mm) in from each side. Four more 3/4-in. (19-mm) holes, 2 1/2 in. deep to hold 1/2-in. threaded lead shield shall be cast into the foundation extension to hold the drive base.

5.2 *Tester*—The tester itself shall be a 150 ± 5-lbs (68.1 ± 2.3-kg) carriage, consisting of a piece of 1/2-in. thick, hot-rolled steel plate in the shape of an equilateral triangle with 6-in. (152-mm) radius rounded corners and having a 3 3/8-in. (85.7-mm) diameter hole in the exact center. Three swivel caster wheels shall be equally spaced in a circle with 15-in. (381-mm) radius from the center and fastened to the underside of the carriage at the intersection of the bisector of each angle and the 15-in. (381-mm) radius circle. Over each wheel a 16-in. (406-mm) high, 1-in. (25.4-mm) diameter, fully threaded steel rod shall be vertically threaded into the carriage to permit the addition of up to 250 lbs (113.5 kg) of auxiliary weights to each wheel. The auxiliary weights with 1 1/2-in. (38-mm) diameter center openings shall weigh either 25 or 50 lbs (11.5 or 23 kg) each and when stacked on the threaded rod, their total thickness shall not exceed 15 in. in height. They shall be held down firmly by a washer and nut on the threaded rods. If the weight of the carriage with wheels and threaded steel rods, but without auxiliary weights, does not reach the required weight of 150 ± 5 lbs (68.1 ± 2.3 kg), one third of the necessary additional weight shall be permanently added near each steel rod by welding it in place. Conversely, if the total weight of the

carriage exceeds the required weight of 150 ± 5 lbs (68.1 ± 2.3 kg), a sufficient number of 1-in. diameter holes may be drilled into the steel plate, equally distributed along the three sides of the triangle, to reduce the weight. A cutaway diagram of the apparatus is shown in Fig. 1.²

5.3 *Drive*—The tester shall be driven by a 3/4-hp motor and speed reducer. Drive transmittal shall be arranged in such a manner that the plane of travel and the elevation of the carriage are free to accommodate various types of test slabs. The carriage shall rotate at the rate of 15 ± 0.5 rpm.

5.4 *Wheels*—The wheels shall be swivel casters with removable axles, equipped with grease fittings. They shall be 4 in. in diameter and have a 1 3/8-in. bearing surface. Three different sets of three wheels each are required, namely one set with a soft rubber bearing surface of 78 ± 3 Shore A durometer hardness, one set with hard rubber bearings surface of 80 ± 3 Shore D durometer hardness, and one set with steel bearing surface. All casters shall be of ball bearing construction.

5.5 *Weights*—Thirty 25-lbs (11.5-kg) or fifteen 50-lbs (23-kg) disk-shaped, 11-in. (280-mm) diameter bar bell weights with 1 1/4-in. (32-mm) diameter center openings to fit the 1-in. diameter rods over each wheel are required. Accuracy of the weights shall be ± 1 %.

5.6 *Deflection Gage*—A jig, equipped with a dial indicator reading in 0.001 in. (0.025 mm) for insertion between the upper and lower sheet of a plywood base to measure the deflection of the base under the path of the wheels. An assembly drawing is shown in Fig. 2.⁴

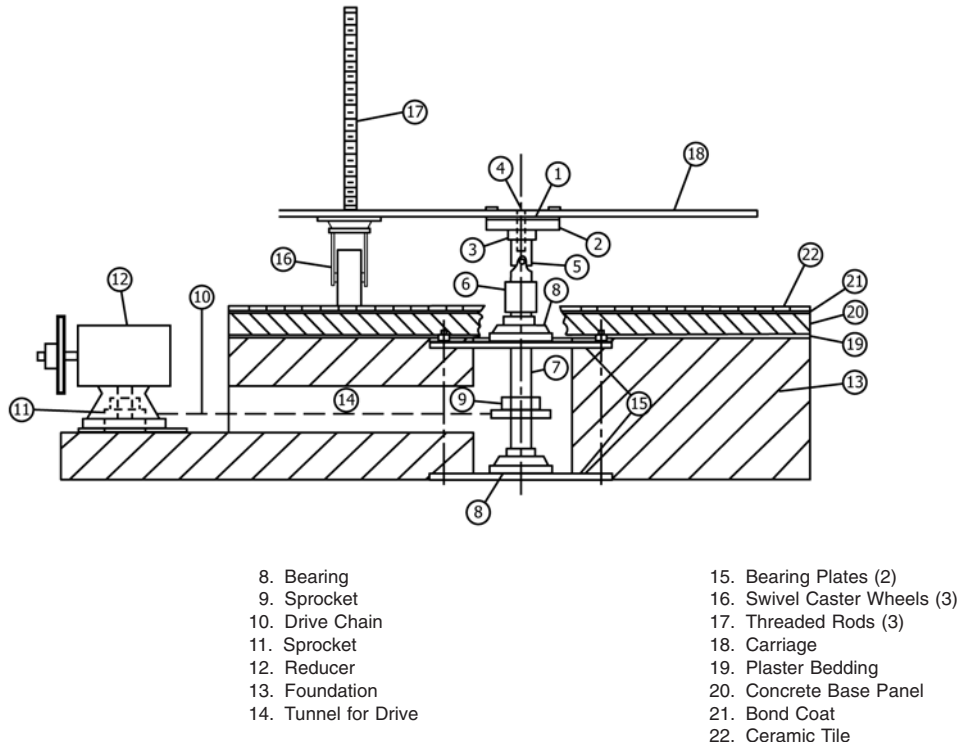

FIG. 1 Floor Tile Installations Systems Tester (Not to Scale)